

PLATEAUX TECHNIQUES / SPECIAL CARE AND O.T AREA



Multicare

The ultimate in product technology



TLV Healthcare

Multicare

Thanks to its modular design, Multicare optimises nursing staff comfort and ensures full patient safety. Multipurpose solutions are offered and its excellent performance / price ratio have made this concept preferred by many hospitals worldwide.

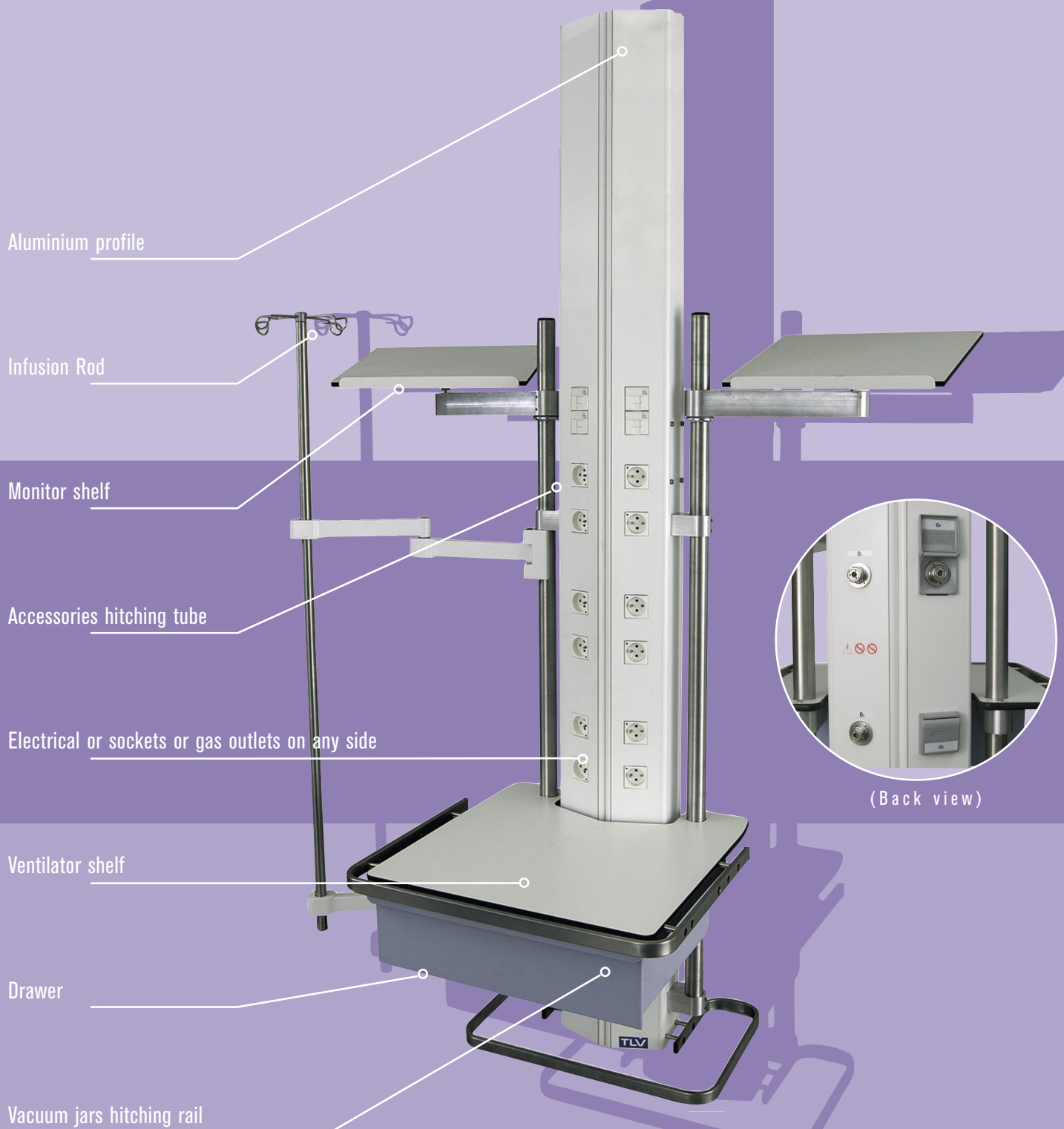

ICU - Firminy Hospital (France)

Configuration with caring lighting, infusion hitching box and monitor shelf



Comfort

- **Ergonomic** customised solutions to individual end users needs
- Optimised work area thanks to **compact dimension**
- Facilitat easy cleaning **Smooth surfaces**
- **Full range** of adjustable accessories

- Large field of vision for **efficient control** of medical equipments
- Exellent infection control due to **special coating** used
- **Easy access** for standard component replacement
- Backed by 25 years of **customer satisfaction**

Safety

- **Easy integrated** within new or refurbished building
- Multicare can be tailored for **one or two** bed installations
- The use of **copper tubes** avoid the adding of gas outlets on the wall
- **Trouble free** maintenance thanks to clip-on covers

Cost
Effective

- Weight : 80 kg (including fixing)
- Payload : 120 kg
- Fixing system : adjustable anchor plate for direct bolting on concrete or metal structure
- Bolting : 4 M 12 heavy loading metal anchors

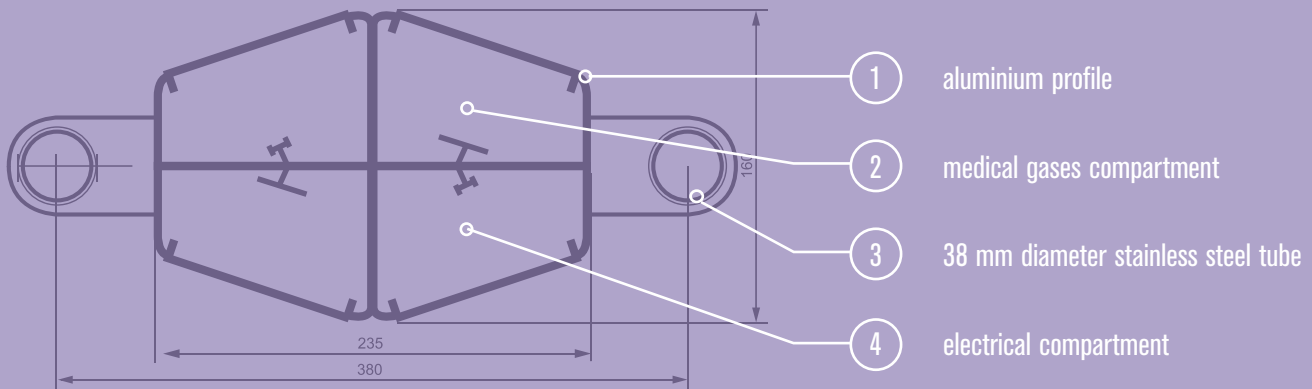

Modular approach with back to back linking or 2 identical profiles fulfils needs of every ICU users

Two opportunities :

- Front side with medical gases for visual control of medical accessories (for example : one trunking providing two beds)
- Front side with the mostly used electrical sockets and gas outlets (for example : one bed per room configurations)

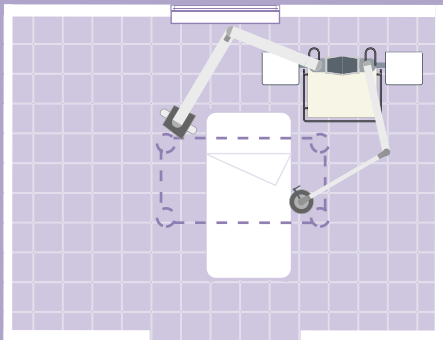

Resuscitation

ICU configuration with bed in room axis, allowing position evolution to enable patient windows view

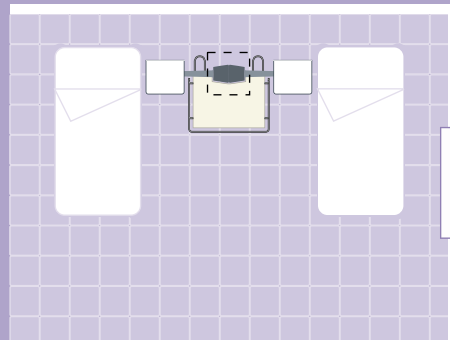

Recovery

- 1 trunking for 2 beds
- Full access to patient head on free side